

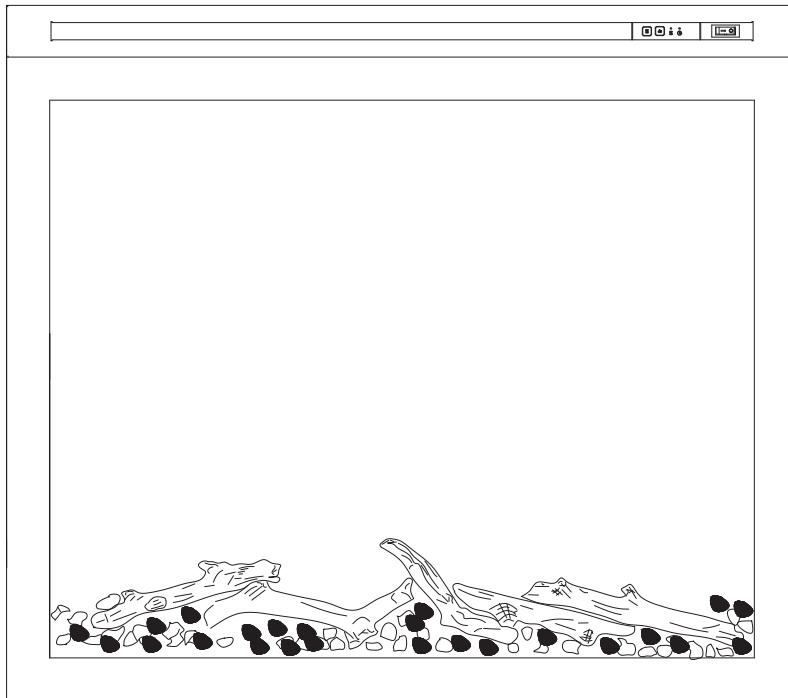

RECESSED ELECTRIC FIREPLACE

Owner's Manual



Model Number	Item Number
EF-136P	EF10141



READ & SAVE THESE INSTRUCTIONS

Carefully read and review before assembling, installing, operating, or maintaining this product. Observe all safety instructions and information.

FAILURE TO FOLLOW WARNINGS & OPERATIONAL INSTRUCTIONS CONTAINED IN THIS MANUAL CAN RESULT IN PROPERTY DAMAGE OR PERSONAL INJURY

****IMPORTANT NOTICE****

For customer service & warranty issues, please contact: customercare@jrhome.com

Electric fireplace inserts and free standing electric fireplaces heaters rated at 1500w/ 5000 BTU

Introduction

WARNING

- **THIS APPLIANCE IS HOT WHEN OPERATED AND CAN CAUSE SEVERE BURNS IF CONTACTED.**
- Do not operate appliance before reading and understanding operating instructions. Failure to operate appliance according to operating instructions could cause fire or injury.
- Risk of burns. Power to the appliance should be turned off and the appliance allowed to cool before servicing. To disconnect power to the appliance, turn controls to off, then remove plug from outlet.
- Do not install damaged, incomplete or substitute components.
- Do not burn wood or other materials in this appliance.
- Young children should be carefully supervised when they are in the same room as the appliance. Toddlers, young children and others may be susceptible to accidental contact burns. A physical barrier is recommended if there are at risk individuals in the house. To restrict access to an appliance or stove, install an adjustable safety gate to keep toddlers, young children and other at risk individuals out of the room and away from hot surfaces.
- Clothing or other flammable material should not be placed on or near the appliance.
- Due to high temperatures, the appliance should be located out of traffic and away from furniture and draperies.
- Ensure you have incorporated adequate safety measure to protect infants/toddlers from touching hot surfaces.
- Even after the appliance is out, the glass and/or screen will remain hot for an extended period of time.
- Check with your local hearth specialty dealer for safety screens and hearth guards to protect children from hot surfaces. These screens and guards must be fastened to the floor.
- Any safety screen or guard removed for servicing must be replaced prior to operating the appliance.
- It is imperative that the control compartments, circulating blower and its passageway in the appliance and are kept clean. The appliance should be inspected before use and at least annually by a qualified service person. More frequent cleaning may be required due to excessive lint from carpeting, bedding material, etc. The appliance area must be kept clear and free from combustible materials, gasoline and other flammable vapors and liquids.
- Under no circumstances should this appliance be modified.
- Do not use this appliance if any part has been under water. Immediately call a qualified service technician to inspect the appliance and to replace any part of the control system which has been under water.
- Do not operate the appliance with the glass door removed, cracked or broken. Replacement of the glass should be done by a licensed or qualified service person.
- Do not strike or slam shut the appliance glass door.
- Keep the packaging material out of reach of children and dispose of the material in a safe manner. As with all plastic bags, these are not toys and should be kept away from children and infants.
- Servicing should be done only while the appliance is disconnected from the power supply circuit.
- Always unplug appliance when not in use.
- Do not operate this appliance with a damaged cord or plug after the appliance malfunctions, has been dropped or damaged in any manner. Return appliance to authorized service facility for examination, electrical or mechanical adjustment, or repair.
- Do not use outdoors.
- Never locate appliance where it may fall into a bathtub or other water container.
- Do not run cord under carpeting. Do not cover cord with throw rugs, runners, or the like. Arrange cord away from traffic area and where it will not be tripped over.
- Connect to properly grounded outlets only.
- Do not insert or allow foreign objects to enter any ventilation or exhaust opening as this may cause an electric shock or fire, or damage the appliance.
- To prevent a possible fire, do not block air intakes or exhaust in any manner. Do not use on soft surfaces, like a carpet, where openings may become blocked.
- Always plug appliances directly into a wall outlet/receptacle. Never use an extension cord, relocatable power tap (outlet/power strip) or adapter.
- Ensure clearances to combustibles are maintained when building a mantel or shelves above the appliance. Elevated temperatures on the wall or in the air above the appliance can cause melting, discoloration or damage to decorations, a T.V. or other electronic components.

Dimensions

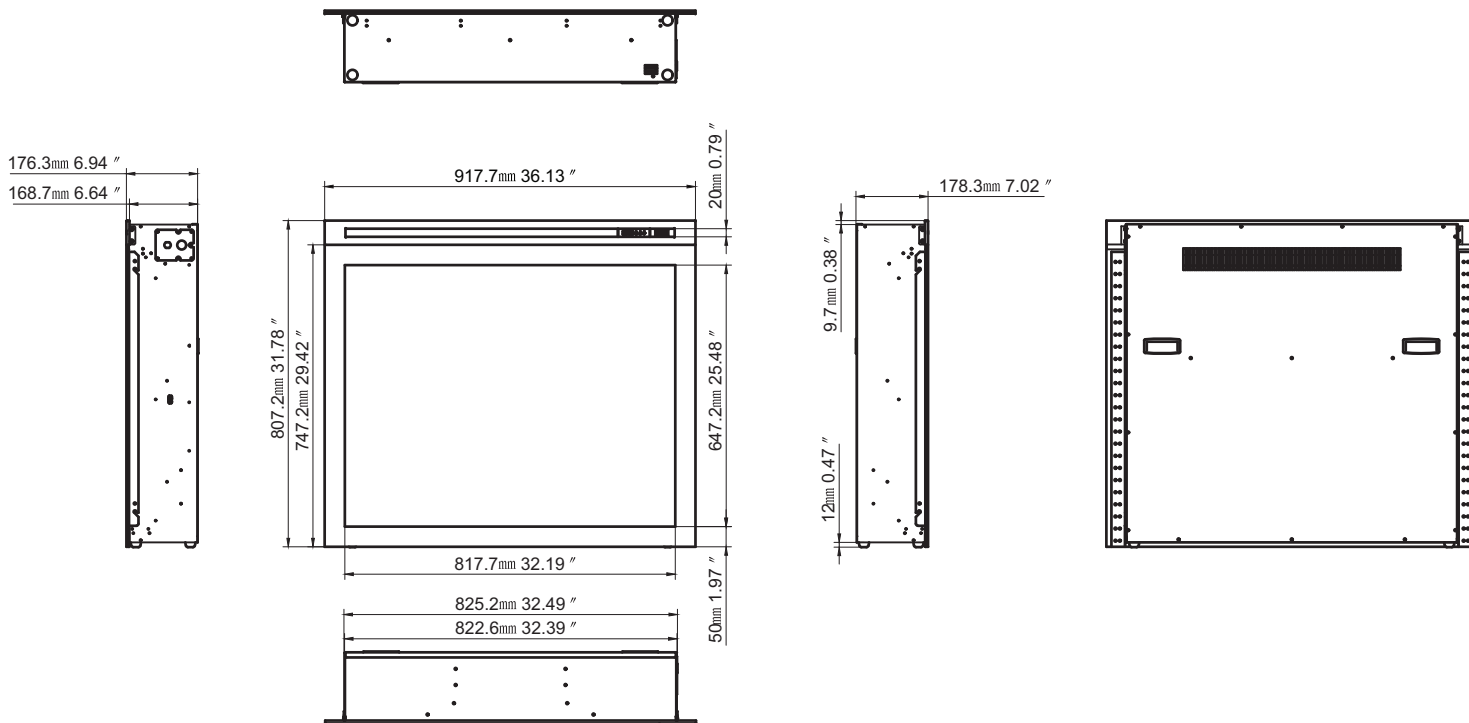

This appliance has been tested in accordance with the CSA Standards for fixed and location-dedicated electric room appliances in the United States and Canada. If you need assistance during installation, please contact your local dealer.

NOTE: This appliance must be electrically wired and grounded in accordance with local codes or, in the absence of local codes, with National Electric Code ANSI/NFPA 70-latest edition in the United States or the Canadian Electric Code, CSA C22.1 in Canada.

Technical Specification

Description of product	ELECTRIC FIREPLACE
Model	EF-136P
Rated Voltage	120V~
Rated Frequency	60 Hz
Rated Power	1500W
Lamp	LED

General Instructions

WARNING

READ THESE INSTRUCTIONS COMPLETELY BEFORE BEGINNING INSTALLATION. FAILURE TO FOLLOW THEM COULD CAUSE AN APPLIANCE MALFUNCTION RESULTING IN SERIOUS INJURY AND/OR PROPERTY DAMAGE.

ALL ELECTRIC APPLIANCES HAVE HOT AND ARCING OR SPARKING PARTS INSIDE. DO NOT USE IT IN AREAS WHERE GASOLINE, PAINT OR FLAMMABLE LIQUIDS ARE PRESENT.

THIS ELECTRIC APPLIANCE IS TESTED AND LISTED FOR USE ONLY WITH THE OPTIONAL ACCESSORIES LISTED IN THESE INSTRUCTIONS. USE OF OPTIONAL ACCESSORIES NOT SPECIFICALLY TESTED FOR THIS ELECTRIC APPLIANCE COULD VOID THE WARRANTY AND/OR RESULT IN A SAFETY HAZARD.

DO NOT OPEN. RISK OF ELECTRIC SHOCK. NO USER-SERVICEABLE PARTS INSIDE.

DO NOT USE DAMAGED ELECTRICAL CORDS.

SERVICING SHOULD BE DONE ONLY WHILE THE APPLIANCE IS DISCONNECTED FROM THE POWER SUPPLY CIRCUIT.

TO PREVENT ELECTRIC SHOCK MATCH THE WIDE BLADE OF PLUG TO WIDE SLOT OF RECEPTACLE AND FULLY INSERT.

1. Prior to plugging your appliance into an electrical outlet, verify that the house circuit breakers for the outlet are on.
2. The appliance may emit a slight, harmless odour when first used. This odour is normal and it is caused by the initial heating of internal appliance elements and will not occur again.
3. If your appliance does not emit heat, consult the operation section of this manual for further information.
4. Use with a CSA or UL certified surge protector.
5. Do not route the power cord directly underneath the appliance.





This electric appliance meets the construction and safety standards of H.U.D. for application in manufactured homes when installed according to these instructions.

As with most electronic devices, your new electric fireplace has been designed to operate at temperatures between 5°C (41°F) and 35° C (95°F). During the colder winter months, allow the fireplace to reach room temperature before turning it on.

Unpacking and Testing Appliance

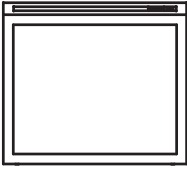
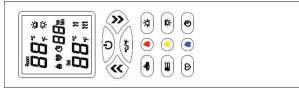
Carefully remove the appliance from the box. Prior to installing the appliance, test to make sure the appliance operates properly by plugging the power supply cord into a conveniently located 120 Volt grounded outlet.

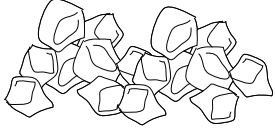
Hardware Parts List

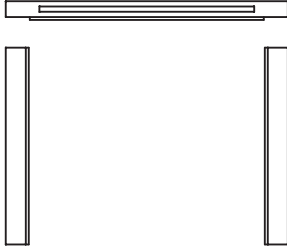
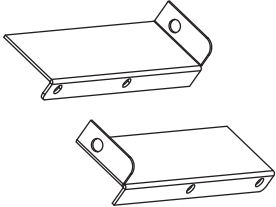
 <p>A- Fireplace EF-136P X 1</p>	 <p>B- Remote Control EF-136P X 1</p>	 <p>C- AAA Battery EF-136P X 2</p>	 <p>D- Crystals EF-136P X 1</p>
 <p>E - Black Crystals EF-136P X 1</p>	 <p>F- Logs EF-136P X 5</p>	 <p>G- Trim EF-136P X 3</p>	 <p>H- Brackets EF-136P X 2</p>

Locating Appliance

WARNING

DUE TO HIGH TEMPERATURES, THIS ELECTRIC APPLIANCE SHOULD BE LOCATED OUT OF TRAFFIC. KEEP COMBUSTIBLE MATERIALS SUCH AS FURNITURE, PILLOWS, BEDDING, PAPERS, CLOTHES AND CURTAINS AT LEAST 36" (914mm) FROM THE FRONT OF THE APPLIANCE.

NEVER LOCATE THIS ELECTRIC APPLIANCE WHERE IT MAY FALL INTO A BATHTUB OR OTHER WATER CONTAINER.

WEAR SAFETY GLOVES AND SAFETY GLASSES FOR PROTECTION DURING INSTALLATION AND MAINTENANCE.

TO PREVENT CONTACT WITH SAGGING OR LOOSE INSULATION, THE ELECTRIC APPLIANCE MUST NOT BE INSTALLED AGAINST VAPOR BARRIER OR EXPOSED INSULATION. LOCALIZED OVERHEATING COULD OCCUR AND A FIRE COULD RESULT.

DO NOT EXPOSE THE ELECTRIC APPLIANCE TO THE ELEMENTS (SUCH AS RAIN, ETC.)

Grounding Appliance

This appliance is for use on 120 Volts. The cord has a plug as shown in (A).

To disconnect appliance, turn controls to off, then remove plug from outlet.

GROUNDING METHODS

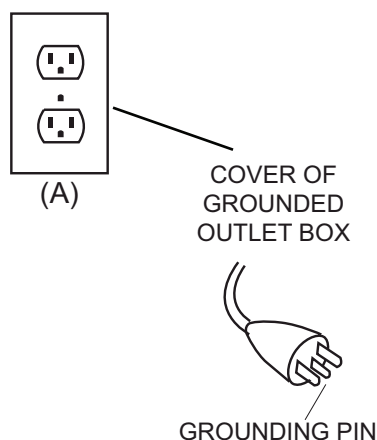

Installation

WARNING

RISK OF FIRE! THE POWER CORD MUST NOT BE PINCHED AGAINST A SHARP EDGE. SECURE CORD TO AVOID TRIPPING OR SNAGGING TO REDUCE THE RISK OF FIRE, ELECTRIC SHOCK OR PERSONAL INJURY. DO NOT RUN CORD UNDER CARPETING. DO NOT COVER CORD WITH THROW RUGS, RUNNERS OR THE LIKE. ARRANGE CORD AWAY FROM TRAFFIC AREAS AND WHERE IT WILL NOT BE TRIPPED OVER.

RISK OF FIRE! TO PREVENT A POSSIBLE FIRE, DO NOT BLOCK AIR INTAKE OR EXHAUST IN ANY MANNER. DO NOT USE ON SOFT SURFACES WHERE OPENINGS MAY BECOME BLOCKED.

RISK OF FIRE! DO NOT BLOW OR PLACE INSULATION AGAINST THE APPLIANCE.

THIS ELECTRIC APPLIANCE IS TESTED AND LISTED FOR USE ONLY WITH THE APPROVED OPTIONAL ACCESSORIES. USE OF OPTIONAL ACCESSORIES NOT SPECIFICALLY TESTED FOR THIS ELECTRIC APPLIANCE COULD VOID THE WARRANTY AND/OR RESULT IN A SAFETY HAZARD.

IF THE INFORMATION IN THESE INSTRUCTIONS IS NOT FOLLOWED EXACTLY, A FIRE OR EXPLOSION MAY RESULT CAUSING PROPERTY DAMAGE, PERSONAL INJURY OR DEATH. DO NOT STORE OR USE GASOLINE OR OTHER FLAMMABLE VAPORS IN THE VICINITY OF THIS OR ANY OTHER APPLIANCE.

THIS APPLIANCE IS HEAVY. IT IS HIGHLY RECOMMENDED THAT TWO PEOPLE INSTALL THIS APPLIANCE.

HEATER VENTS ON THE ELECTRIC APPLIANCE CANNOT, IN ANY WAY, BE COVERED AS IT MAY CREATE A FIRE HAZARD.

DO NOT RUN THE POWER CORD HORIZONTALLY, DIRECTLY BELOW THE APPLIANCE.

Your EF-136P unit is an insert. Select a suitable location that is not susceptible to moisture and is away from drapes, furniture and high traffic areas.

NOTE: Follow all National and local electrical codes.

Minimum Clearance to Combustibles

Measurements are taken from the glass front

Bottom	0"	Top	8" (203mm) to mantel
Sides	0"	Top	8" (203mm) to ceiling
Back	0"		

Minimum Mantel Clearances

WARNING

WHEN USING PAINT OR LACQUER TO FINISH THE MANTEL, THE PAINT OR LACQUER MUST BE HEAT RESISTANT TO PREVENT DISCOLOURATION.

Installation

Recessing the Appliance Flush into the Wall

Due to the many different finish materials used on walls, it is highly recommended that you consult your local builder before you install this appliance in the wall.

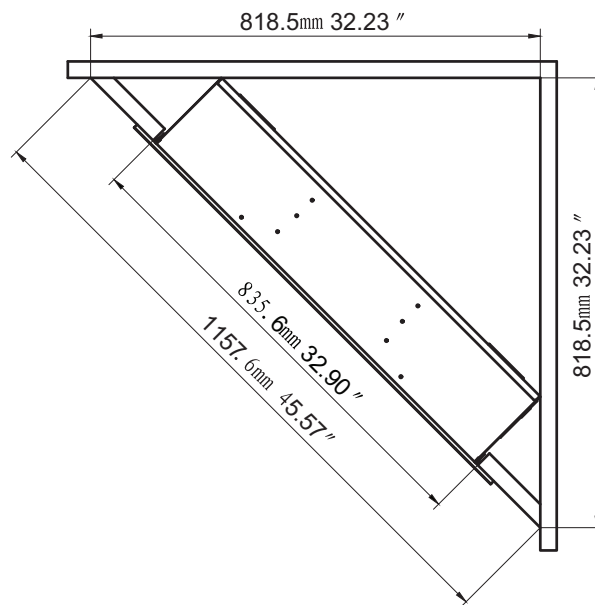
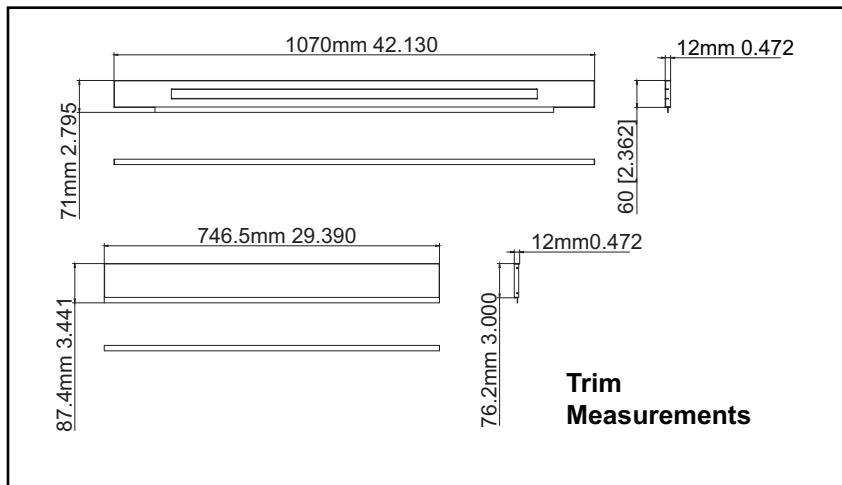
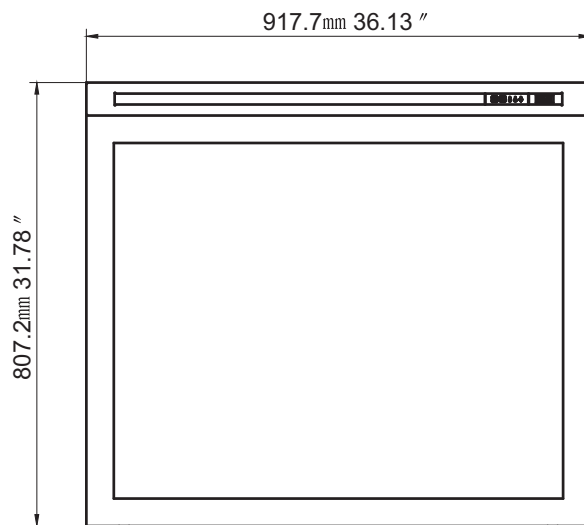
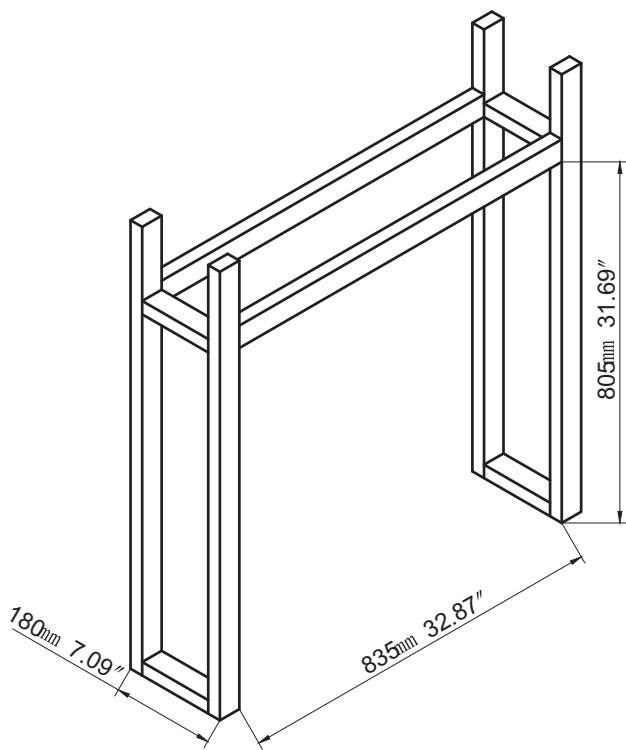

Finishing

WARNING

POWER SUPPLY SERVICE MUST BE COMPLETED PRIOR TO FINISHING TO AVOID RECONSTRUCTION.

HEAT VENTS AND AIR OPENINGS CANNOT BE COVERED IN ANY CIRCUMSTANCES.

Front Glass Removal / Installation

WARNING

BEFORE THE FRONT GLASS IS INSTALLED OR REMOVED, UNPLUG THE APPLIANCE AND WAIT UNTIL APPLIANCE IS COOL TO THE TOUCH. GLASS CAN BE HEAVY AND FRAGILE SO HANDLE WITH CARE.

1. Remove the 4 screws from the sides of the appliance in Figure 1.
2. Have two people lift the glass up and away from the appliance, holding the glass vertical while carrying. Carefully rest the glass on a soft, non-abrasive surface.
3. Re-install the front glass by aligning the slots with the pins on the side of the appliance. Press the glass down to secure in place.
4. Secure the front glass using the 4 screws in Figure 1. (If fully recessed, this is not necessary)

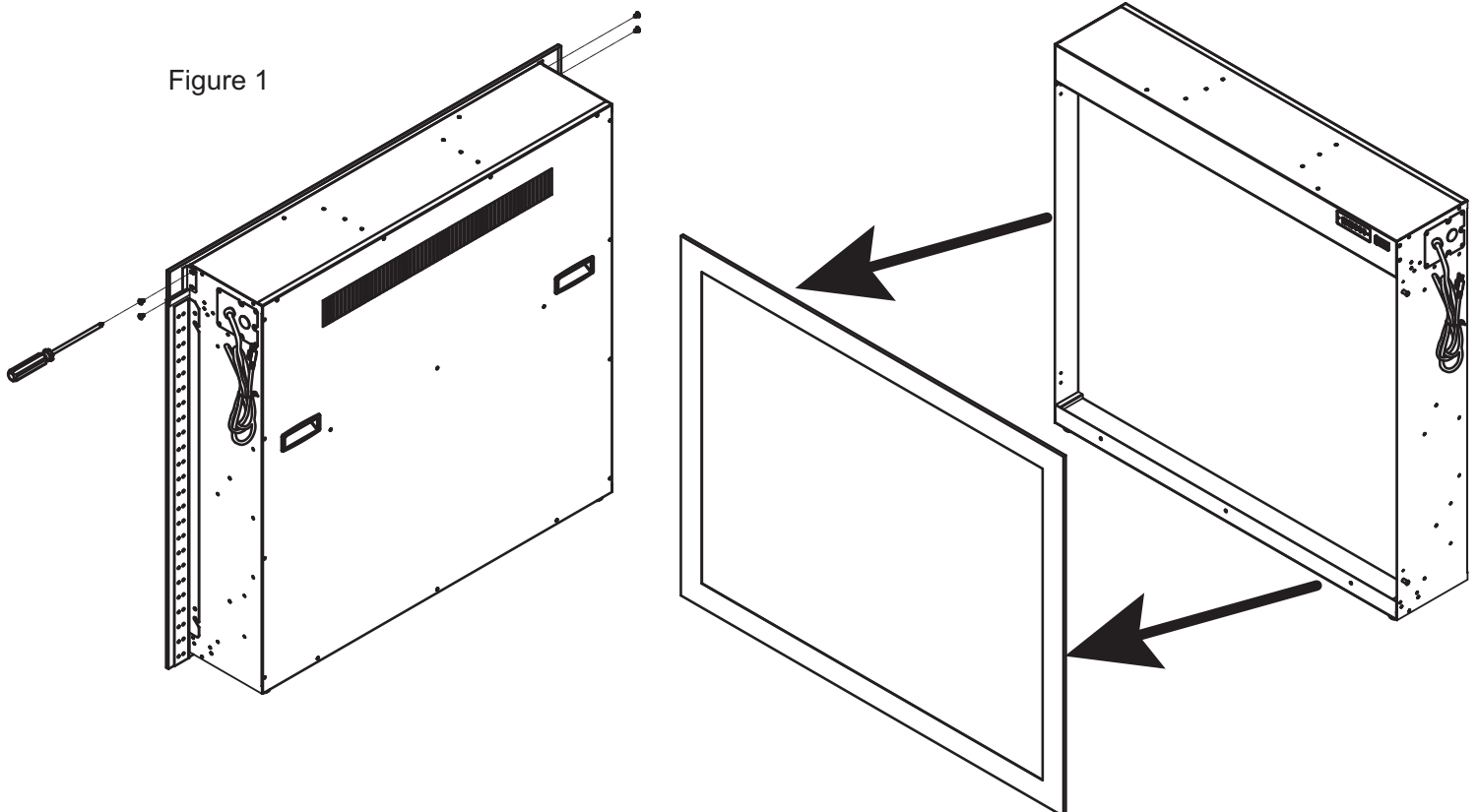

Trim Installation

WARNING

BEFORE THE FRONT GLASS IS INSTALLED OR REMOVED, UNPLUG THE APPLIANCE AND WAIT UNTIL APPLIANCE IS COOL TO THE TOUCH. GLASS CAN BE HEAVY AND FRAGILE SO HANDLE WITH CARE.

STEP 1

Remove top panel.
Set screws aside for
STEP 2

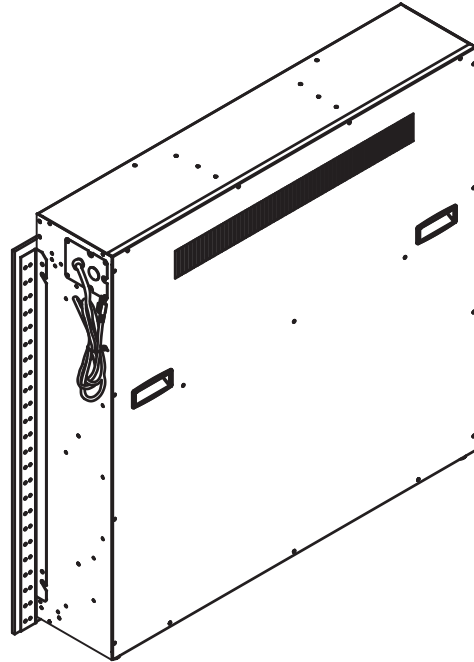
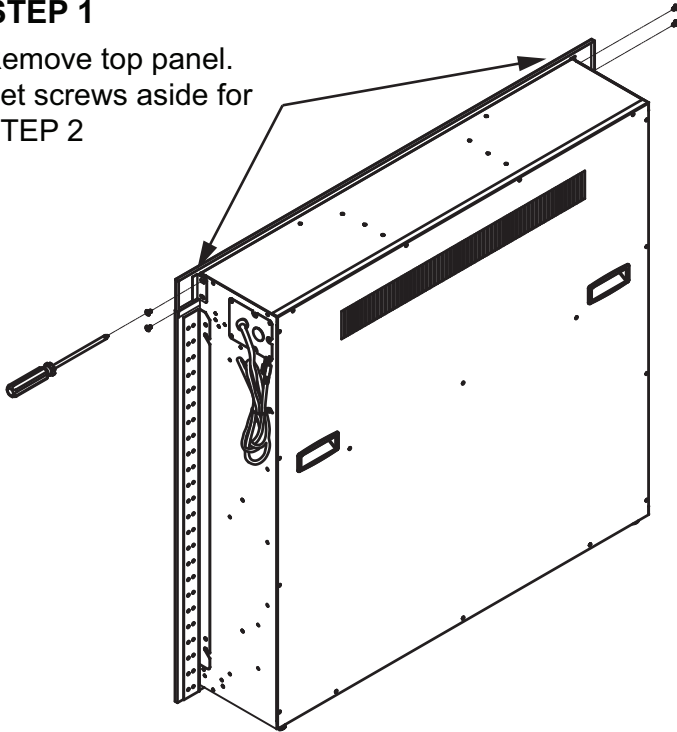

STEP 2

1. Attach Bracket (2 X PART H) using the 4 screws removed in STEP 1 to the Side Trim (2 X Part G).

2. Attach the side trim with brackets and the top trim to the firebox using (2 x 5 screws).

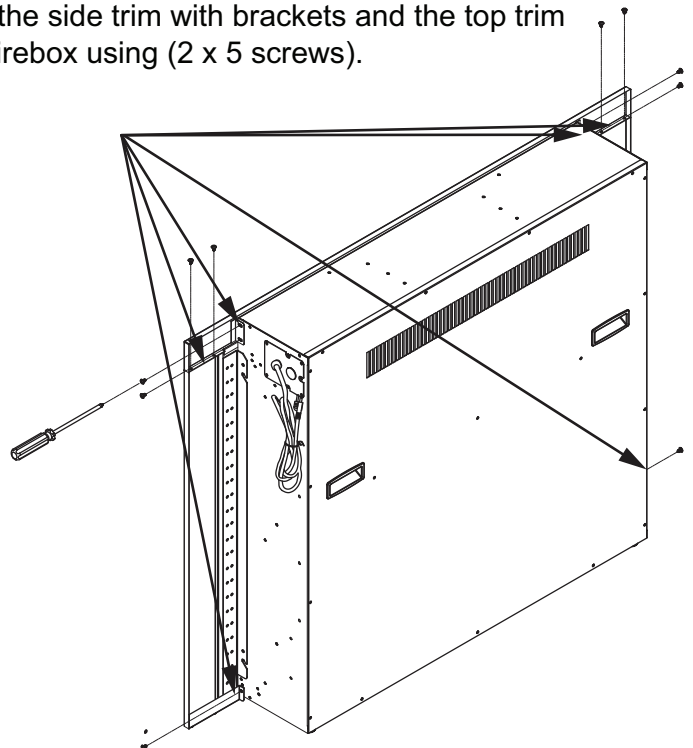
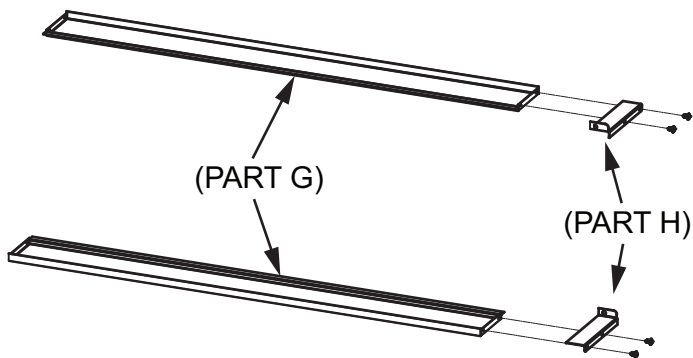

Operating Instructions



WARNING

WHILE THE APPLIANCE IS OPERATING DO NOT REMOVE THE GLASS PANEL. THIS WILL CAUSE THE REMOTE CONTROL TO FUNCTION IMPROPERLY.

Once the appliance has been plugged into a grounded electrical outlet, it is ready to operate.

NOTE: Ensure the house circuit breakers for the power supply are turned on. In the event of a powerfailure, the appliance will lose its memory function and will reset to factory mode when the power returns.

Main Power Switch

To turn unit power on:

1. Plug in power cord. If hard wired, just turn on the power switch on the unit.
2. Verify the power is turned on when two ring tones are initiated.

Operating with Button



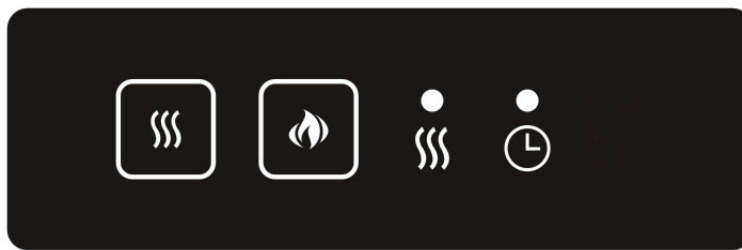

Heater Indicator



Heater







Flame

Timer

FUNCTION	ICON	DISPLAY	OPERATION DETAILS
Flame	 The LED flame	N/A	Turn on the flame total 7 levels with high brightness Level. (Red, Yellow, Blue, Red yellow, Red blue, Yellow blue, Red yellow blue)
Heater	Press button to adjust heater and blower	 First press	Turns on 2 heating system elements at Highest Level 1500W. Indicator shows red.
		 Second press	Turns on 1 heating system element at Lowest Level 750W. Indicator shows blue.
		 Third press	Turns off heating system and blower
Timer			Heater timer is set

The onboard buttons are located under the trim on the top right



Multi-functional Operating with Remote Control

FUNCTION	ICON	DISPLAY		OPERATION DETAILS
Power		ON	 First click	Turn on the yellow flame at the brightest level. Ember bed color is red. Top light color is white. Heater is off.
		OF	 Second click	Turn off the fireplace main power
Flame		ON	 First click	Turns on flame colour, ember bed LEDs and top light.
		OF	 Second click	Turns off flame, ember bed LEDs and top light.

Note: Third click, LED setting will resume to previous setting

Temperature	°C / °F Click to toggle between Celsius and Fahrenheit.	88°C	Celsius degree
		88°F	Fahrenheit degree



Note: Room temperature will display the current room temperature in Celsius or Fahrenheit degree

Temperature	  Adjust heater and display temperature	16	16°C	16 Celsius degrees
		19	19°C	19 Celsius degrees
		21	21°C	21 Celsius degrees
		23	23°C	23 Celsius degrees
		25	25°C	25 Celsius degrees
		27	27°C	27 Celsius degrees
		30	30°C	30 Celsius degrees
		61	61°F	61 Fahrenheit degrees
		66	66°F	66 Fahrenheit degrees
		70	70°F	70 Fahrenheit degrees
		73	73°F	73 Fahrenheit degrees
		77	77°F	77 Fahrenheit degrees
		80	80°F	80 Fahrenheit degrees
		86	86°F	86 Fahrenheit degree

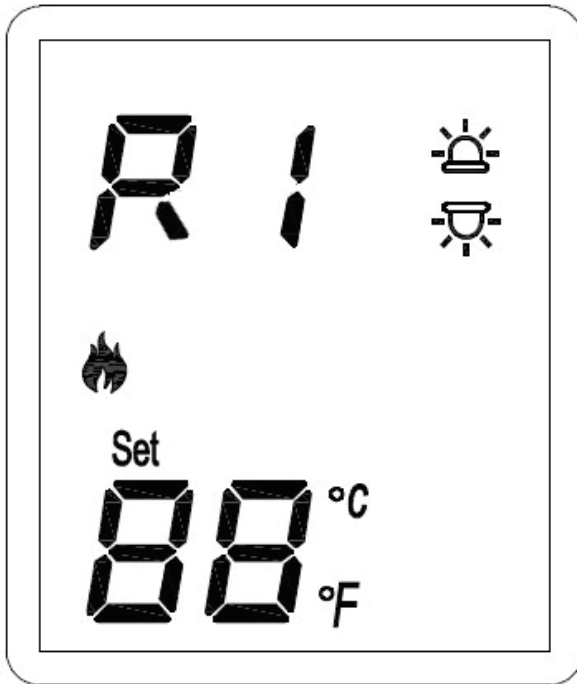

Multi-functional Operating with Remote Control



FUNCTION	ICON	DISPLAY		OPERATION DETAILS
RGB FLAME	Red flame 	R0	<i>R0</i>	Red flame off
		R1	<i>R1</i>	Lowest red flame
		R2	<i>R2</i>	Medium red flame
		R3	<i>R3</i>	Brightest red flame
	Yellow flame 	Y0	<i>Y0</i>	Yellow flame off
		Y1	<i>Y1</i>	Lowest yellow flame
		Y2	<i>Y2</i>	Medium yellow flame
		Y3	<i>Y3</i>	Brightest yellow flame
	Blue flame 	B0	<i>B0</i>	Blue flame off
		B1	<i>B1</i>	Lowest blue flame
		B2	<i>B2</i>	Medium blue flame
		B3	<i>B3</i>	Brightest blue flame

Multi-functional Operating with Remote Control

FUNCTION	ICON	DISPLAY		OPERATION DETAILS
Top Light		C1	01	Red
		C2	02	Orange
		C3	03	Yellow
		C4	04	Forest green
		C5	05	Green
		C6	06	Blue
		C7	07	Sea blue
		C8	08	Cyan
		C9	09	White
		CA	0A	Purple
		Cb	0B	Pink
		CC	0C	Color- rotating
		CL	0D	Rainbow





Note: After 'CL', press one more time top light will turn off

Ember Bed		E1	E1	Red
		E2	E2	Orange
		E3	E3	Yellow
		E4	E4	Forest green
		E5	E5	Green
		E6	E6	Blue
		E7	E7	Sea blue
		E8	E8	Cyan
		E9	E9	White
		EA	EA	Purple
		Eb	EB	Pink
		EC	EC	Color- rotating
		EL	EL	Rainbow

Note: After 'EL', press one more time ember bed light will turn off



Multi-functional Operating with Remote Control

FUNCTION	ICON	DISPLAY	OPERATION DETAILS
Heater	 (short press)	 First click	Turn on two group the heating system at 1500W high level
		 Second click	Turn on one group the heating system at 750W low level
Note: Third click, Turn off all heating system and blower			
Timer		30 min	30 minutes
		1 hrs	1 hour
		2 hrs	2 hours
		3 hrs	3 hours
		4 hrs	4 hours
		5 hrs	5 hours
		6 hrs	6 hours
		7 hrs	7 hours
		8 hrs	8 hours
		9 hrs	9 hours
		N/A	OFF
		Favourite flame lights settings	 (Press and hold for 3 seconds)
Note: If you want to return to preset stage, press the key for 3 seconds. It only memorizes one storage of flame setting, the new setting will override the previous setting.			



Remote Control Specification

- 1.Model: R220
- 2.Remote Key: 13
- 3.Communication: Infrared
- 4.Infrared Distance: 6 Meters
- 5.Battery: AAx 2pcs

NOTE: Make sure your “AAA” batteries (x2) are fully charged and installed correctly in your remote control before operating.

The remote control must remain within 6 meters of the appliance to be effective, this range may be reduced when battery power is depleted.



Maintenance

WARNING

PREPARATION FOR MAINTENANCE

ALWAYS DISCONNECT THE POWER AND ALLOW THE ELECTRIC APPLIANCE TO COOL BEFORE PERFORMING ANY CLEANING, MAINTENANCE OR RELOCATION OF THIS ELECTRIC APPLIANCE. TURN CONTROLS TO OFF AND REMOVE PLUG FROM OUTLET OR TURN OFF THE HOUSE CIRCUIT BREAKER TO ELECTRIC APPLIANCE RECEPTACLE.

DO NOT INSTALL LED LIGHT STRIPS THAT EXCEED SPECIFIED MAXIMUM WATTS.

THE LED LIGHT STRIPS IN YOUR APPLIANCE CAN BECOME EXTREMELY HOT. ALLOW AT LEAST 10 MINUTES BETWEEN TURNING OFF THE APPLIANCE AND REMOVING THE STRIPS TO AVOID ACCIDENTAL BURNS.

DO NOT HANDLE THE LED LIGHT STRIPS WITH BARE FINGERS. USE GLOVES OR A CLEAN DRY CLOTH WHEN HANDLING.

Storage Instructions

Ensure the power cord is not installed so that it is pinched or against a sharp edge and ensure that the power cord is stored or secured to avoid tripping or snagging to reduce the risk of fire, electric shock, or injury to persons.

Construction and electrical outlet wiring must comply with local building codes and other applicable regulations to reduce the risk of fire, electrical shock, and injury to persons.

Do not attempt to wire your own new outlets or circuits. To reduce the risk of fire, electric shock, or injury to persons, always use a licensed electrician.

Wiring Diagram

WARNING

TURN OFF THE APPLIANCE COMPLETELY AND LET COOL BEFORE SERVICING. ONLY A QUALIFIED SERVICE PERSON SHOULD SERVICE AND REPAIR THIS ELECTRIC APPLIANCE.

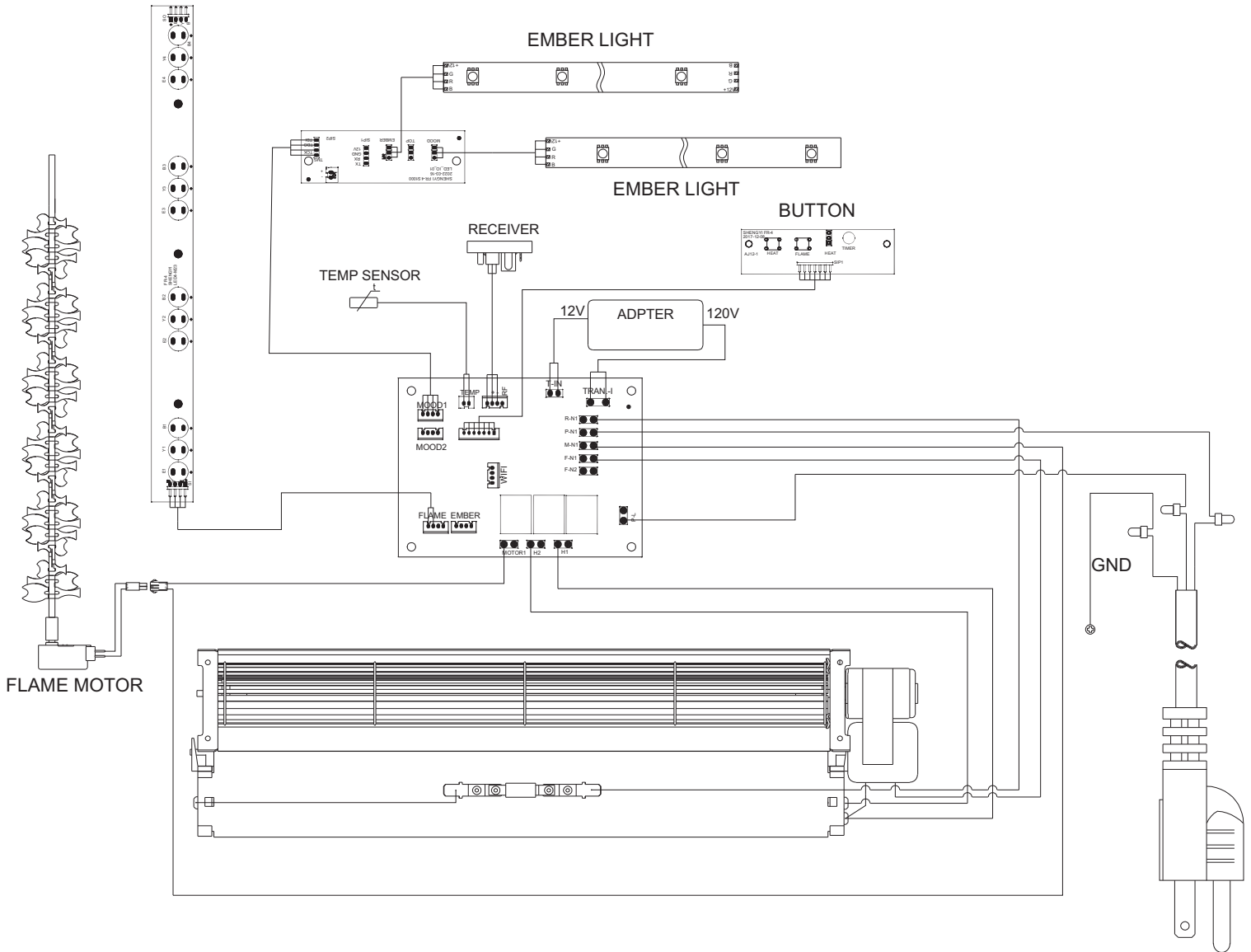

Hard Wiring Installation

WARNING

TURN OFF THE APPLIANCE COMPLETELY AND LET COOL BEFORE SERVICING. ONLY A QUALIFIED SERVICE PERSON SHOULD SERVICE AND REPAIR THIS ELECTRIC APPLIANCE.

HARD WIRING CONNECTION

If it is necessary to hard wire this appliance, a qualified electrician must remove the cord connection, and wire the appliance directly to the house hold wiring.

This appliance must be electrically connected and grounded in accordance with local codes, if hard wired. In the absence of local codes, use the current CSA C22.1 CANADIAN ELECTRICAL CODE in Canada or the current ANSI/NFPA 70 NATIONAL ELECTRICAL CODE in the United States.

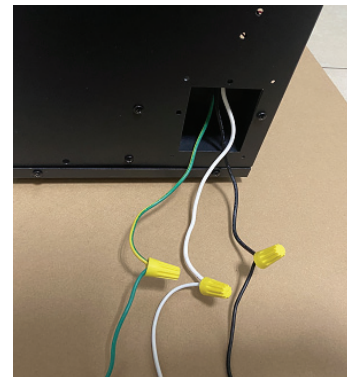
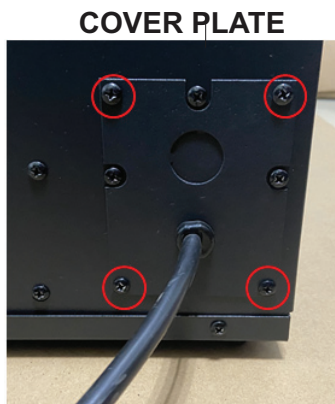
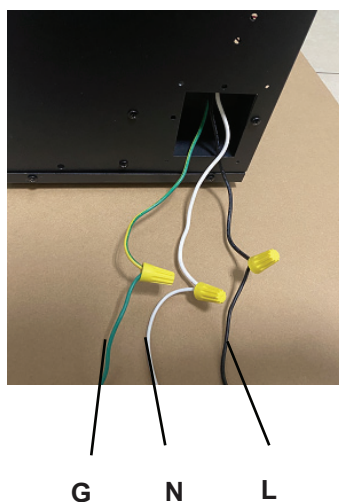

Figure 1

1. Remove the cover plate from the right side of the appliance by removing the four screws, as shown above.
2. Remove the wire connectors from the power cord. The power cord may be discarded.
3. Using the wire connectors, connect the ground green wires (G) and white wires (N) together, then hot black wires (L) and then refer to Figure 2.
4. Reinstall the cover plate using the four screws, as shown in Figure 1.

NOTE: Leave enough wire so that the appliance can be removed from the enclosure without disconnecting the power supply.

Figure 2



Replacement Parts

WARNING

FAILURE TO POSITION THE PARTS IN ACCORDANCE WITH THIS MANUAL OR FAILURE TO USE ONLY PARTS SPECIFICALLY APPROVED WITH THIS APPLIANCE MAY RESULT IN PROPERTY DAMAGE OR PERSONAL INJURY.

To order parts, contact customercare@jrhome.com

FOR WARRANTY REPLACEMENT PARTS, A PHOTOCOPY OF THE ORIGINAL INVOICE WILL BE REQUIRED TO HONOUR THE CLAIM.

When ordering replacement parts always give the following information: • Model and serial number of appliance

- Installation date of appliance
- Part number
- Description of part
- Finish

FOR FURTHER INFORMATION, CONTACT CUSTOMERCARE@JRHOME.COM or call 1-800-561-5550.

COMPONENTS

REF.	LUX36	DESCRIPTION
1	36FG	Front Glass
2	36BBLL	Ember Bed LED Light
3	36FLL	Flame LED light
4	36RBH	Reflective brush combination
5	36BHA	Blower and Heater Assembly
6	36CB	Circuit Board
7	36RC	Remote Control
8	36RCR	Remote Control Receiver
9	36FM	Flame motor 120V/10/12RPM
10	36RML	Ribbon of magic lights circuit board

WARNING

This product can expose you to chemicals including Carbon Black, which is known to the State of California to cause cancer, and Bisphenol A (BPA), which is known to the State of California to cause birth defects or other reproductive harm. For more information go to www.P65Warnings.ca.gov

Replacement Parts Diagram

WARNING

FAILURE TO POSITION THE PARTS IN ACCORDANCE WITH THIS MANUAL OR FAILURE TO USE ONLY PARTS SPECIFICALLY APPROVED WITH THIS APPLIANCE MAY RESULT IN PROPERTY DAMAGE OR PERSONAL INJURY.

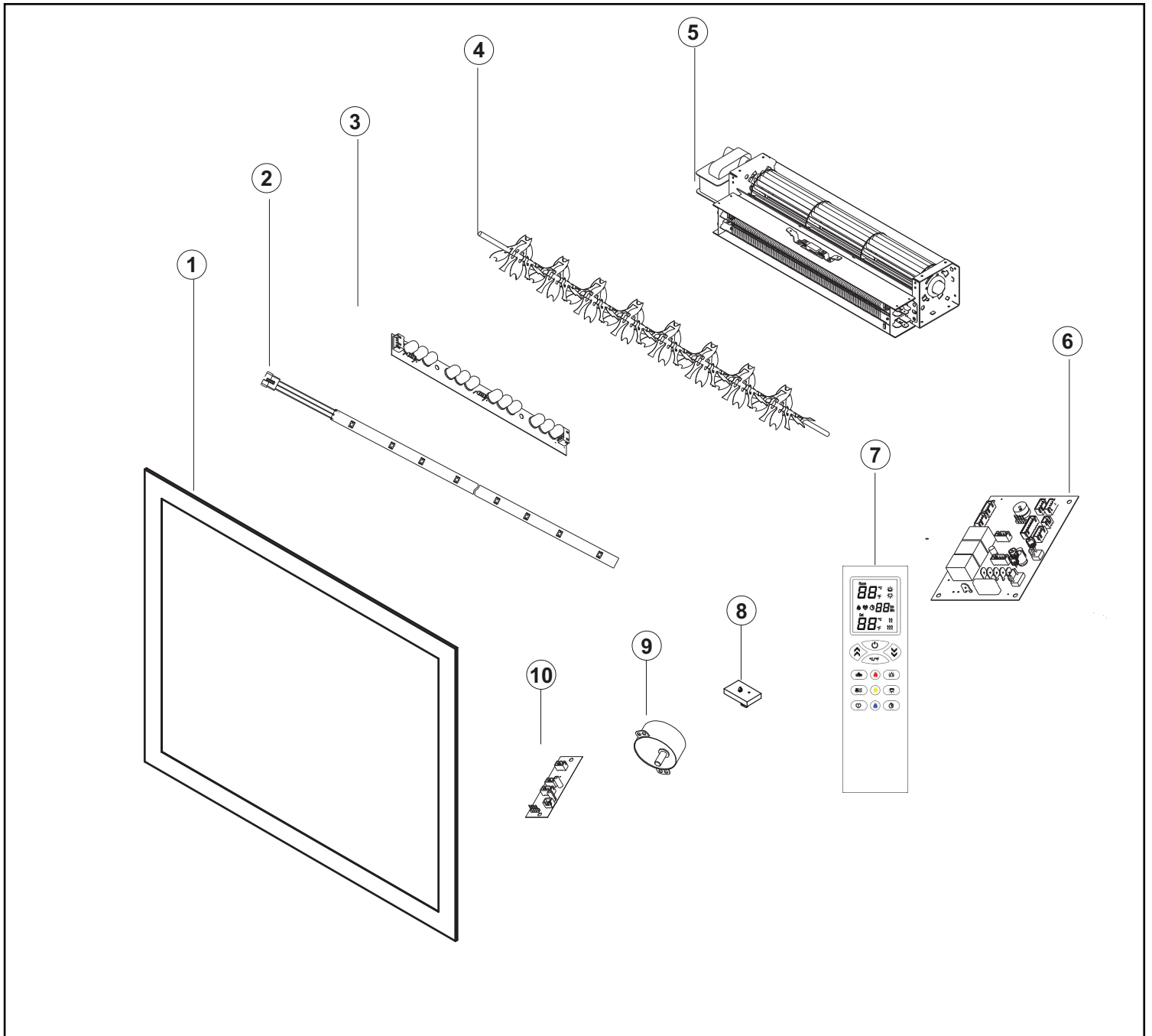

NOTE: Care must be taken when removing and disposing of any broken glass or damaged components. Be sure to vacuum up any broken glass from inside the appliance before operation.

Troubleshooting

WARNING

TURN OFF THE APPLIANCE COMPLETELY AND LET COOL BEFORE SERVICING. ONLY A QUALIFIED SERVICE PERSON SHOULD SERVICE AND REPAIR THIS ELECTRIC APPLIANCE.

Symptom	Problem	Test Solution
Dim or no flame/ Ember bed is not glowing or dimming	LED's are burnt out or malfunctioning	Inspect the LED's and replace them if necessary
No warm air coming out of appliance	Room temperature is higher than the appliance setting (if it is set to room temperature)	Reset temperature setting
	Heater is burnt out	Inspect the burner and heater assembly and replace it if necessary
Appliance turns off and will not turn on	Electric fireplace has overheated and safety device has caused thermal switch to disconnect or home circuit breaker has opened.	Reset switch by turning main power switch off and waiting 5 minutes then turning it back on.
Remote control does not work	Low battery	Replace batteries in remote control
Heater shuts off automatically	Room is too warm	The heater has a built-in thermostat so it will shut off automatically once the pre-set temperature is reached. It will also turn on automatically if the room temperature drops below the pre-set temperature.

Review & Warranty Extension



SeasonGuard
Plus



patioflare

elements
bringing innovation to all parts of your home

Extend Your Warranty By Leaving A Review

We want your opinion about your purchase...and we want you to tell everyone about it! Just leave a review for the product on the retailers website where you made your purchase, or at www.jrhome.com, and fill in the online warranty at <https://www.jrhome.com/warranty-registration> to receive a complimentary extra year of warranty protection.

Follow us on:



www.jrhome.com #ActiveFlame #jrhome

IMPORTANT



For questions, concerns or problems with our product please email our customer service department:

customercare@jrhome.com

DATED PROOF OF PURCHASE REQUIRED FOR WARRANTY SERVICE

Si vous éprouvez des difficultés ou si vous avez des questions ou des préoccupations, prière de faire parvenir un courriel à notre service à la clientèle

customercare@jrhome.com

UNE PREUVE D'ACHAT DATÉE EST REQUISE POUR SE PRÉVALOIR DE LA GARANTIE.

WARRANTY

This product is inspected, tested and carefully packaged to minimize the chance of damage during shipment. If a part (excluding light bulbs, glass and fuses*) within two years from the date of purchase proves to be defective in material or fabrication under normal use, the part will be repaired or replaced. The Company's obligation under the warranty is to replace or repair defective parts at our discretion. Any expenses or damage resulting from the installation, removal or transportation of the product will be the responsibility of the owner and are not covered by this warranty. The owner assumes all other risks arising from the use or misuse of the product. The warranty will be void if the product damage or failure is deemed by the Company to be caused by accident, alteration, misuse, abuse, incorrect installation or removal, or connection to an incorrect power source by the owner. The Company neither assumes, nor authorizes any person or entity to assume for it any obligation or liability associated with its products. Light bulbs and fuses are not covered under this warranty. If you have any questions regarding the warranty or service, please contact us at **customercare@jrhome.com**.

Customer Service :

JR Home Products

Unit 306 - 19100 Airport Way, Pitt Meadows, BC V3Y 0E2

Toll Free : 1-800-561-5550

E-mail : **customercare@jrhome.com**

AVERTISSEMENT

Ce produit a été soigneusement inspecté, testé et emballé afin de minimiser les risques de dommages durant le transport. Si l'une des pièces (à l'exception des verres, des ampoules électriques et des fusibles*) s'avère défectueuse au niveau de sa fabrication ou de ses matériaux dans les deux ans qui suit la date de l'achat suite à une utilisation normale, la pièce sera réparée ou remplacée. La compagnie est tenue de réparer ou remplacer les pièces défectueuses à sa discrétion, en vertu de la garantie. Tous frais ou dommage résultant de l'installation, du démantèlement ou du transport du produit demeurent la responsabilité du client et n'est pas couvert par cette garantie. Le client assume tout autre risque résultant de l'utilisation correcte ou fautive du produit. La garantie devient nulle si la compagnie détermine que le dommage ou le mauvais fonctionnement est causé par un accident, une modification, une mauvaise utilisation, un abus, une mauvaise installation ou un mauvais démantèlement ou un branchement à une source électrique inadéquate de la part du client. La compagnie n'est pas responsable et n'autorise quiconque, personne ou entité légale, à accepter de responsabilité ou obligation en son nom, en rapport avec ses produits. * Les ampoules électriques et les fusibles ne sont pas couverts par cette garantie. Pour toute question au sujet de la garantie ou du service, contacter le service à la clientèle à : **customercare@jrhome.com**.

Service à la clientèle:

JR Home Products

Unit 306 - 19100 Airport Way, Pitt Meadows BC V3Y 0E2 Numéro

sans frais: 1-800-561-5550

Courriel: **customercare@jrhome.com**

You **MUST** register your product within 30 days of purchase to receive warranty service.

Registration can be completed online at **www.jrhome.com** or by mailing this form.

Vous **DEVEZ** enregistrer votre produit dans les 30 jours suivant l'achat pour bénéficier du service de garantie.

L'enregistrement sera complet une fois que vous aurez posté ce formulaire ou que vous serez inscrit en ligne.

Warranty Registration Information Form / Formulaire d'enregistrement de la garantie

Name / Nom : _____

Street / Adresse : _____

City / Ville : _____

Province / Province : _____

Postal Code / Code postal : _____

Daytime Phone # / No téléphone jour : _____

Evening Phone # / No téléphone soir : _____

E-Mail Address / Courriel : _____

Product/Produit : _____

Place of Purchase / Lieu de l'achat : _____

Date of Purchase / Date de l'achat : _____

Model # / No de modèle : _____

Serial # / Numéro de série : _____

You **MUST** register your product to receive warranty service.

For warranty service, contact J&R Home Products at the address, phone numbers listed below within 30 days of purchase. Be sure to have your sales receipt and original date of purchase. All warranty service will be coordinated by J&R Home Products service center.

Vous **DEVEZ** enregistrer votre produit pour vous prévaloir de la garantie.

Afin de faire valoir la garantie, communiquez avec J&R Home Products à l'adresse et aux numéros indiqués ci-dessous dans les 30 jours suivant la date d'achat. Ayez en main votre reçu et la date d'achat. Toutes les demandes liées aux garanties seront traitées par le centre de service de J&R Home Products.